

Water Flow Switch

Models: WFS-06/10/15/20/25/30.

WFS Series - indicating type

MULTI-TECH DEVICES.
CATALOGUE

General:

MTD make indicating type, magnetically actuated flow switches are designed for positive detection of fluid flow through your equipment. These are suitable for water, kerosene, lubricating oils of low viscosity etc. These are available in 6 sizes, i.e. 1/4", 3/8", 1/2", 3/4", 1" and 1 1/4" BSP. Suitable size may be selected from actual flow rate. Flow range covered is from 1 to 150 LPM. Fluid Flow in the System is seen through transparent tube.

Construction:

The clearance between the float and inner surface of the transparent tube are large enough to let floating particles to pass through, eliminating the chances of clogging. This also reduces the pressure drop across the switch. All switches are strong and lightweight. Adequate magnetic shielding is provided as an in-built feature, enabling the user to mount the switch in any location. Usually epoxy powder coated body in brown colour is provided.



Technical Specifications:

Max. System Pressure:	10 Kg/cm ² (150 psi)
Temperature Range:	8°C to 120°C.
Electrical:	Hermetically sealed reed switch, 80AT type 500mm long two core wire.
Contact Rating:	'NO' type contact rated for 1 amp 230 Vac (resistive).

[Please take care of surge currents to avoid damage of Reed switch element. In such cases please apply R.C. Network (Resistor & Capacitor)].

Mounting Instructions

Dimensions and Features:



(Recommended)

Note: Set flow value may differ according to the type of installations.

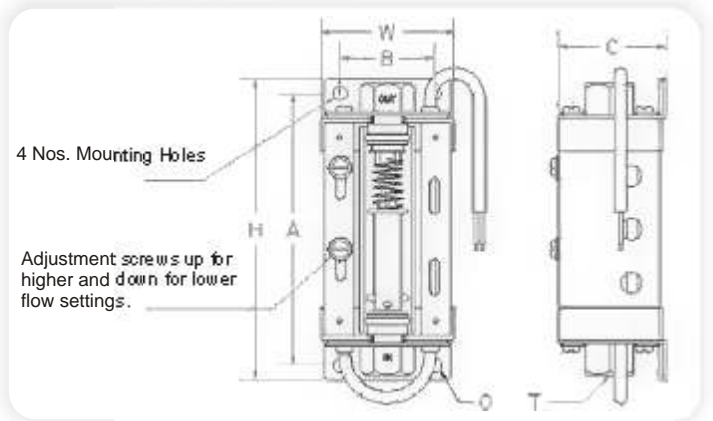

Models Available:

Model No.	T BSP	A	B	O	H	W	C	Standard flow Ranges Covered in LPM
WFS -06	1/4"	95	32	5.5	108	44	42.5	0.5-1, 1-2, 2-4
WFS -10	3/8"	127	44	6.5	141	62.5	48.6	1-2, 2-4, 3-6, 4-8
WFS -15	1/2"	163	46	6.5	177	70	61.5	2-4, 3-6, 5-10, 8-16, 10-20
WFS -20	3/4"	171	56	6.5	189	76	69	10-20, 15-30, 20-40, 25-50
WFS -25	1"	171	56	6.5	189	76	69	10-20, 15-30, 20-40, 25-50
WFS -30	1 1/4"	193	60	8.5	212	82	77	40-80, 50-100, 75-150

Precautions:

- Do not use excessive forces while fixing nozzles/ couplings. Use thread sealing for leak-tight joints. Do not hold switch in vice or wrench.
- Do not exceed electrical rating of the read switch. Use auxiliary relay or contactor for higher current rating and extra number of contacts.
- Do not exceed normal pressure rating of the switch for standard models. Consult manufacturer for higher system pressure.

For further information, please contact...

MULTI-TECH DEVICES. 6, "Godavari", Laxmi Industrial Complex, Vartak nagar, Thane(W) - 400 606.
Tel/fax.: (+91)022 -25856706\56247315. E-Mail: - multitech8719@yahoo.co.in

Ordering Information

EXAMPLE : **WFS -**
BASIC MODEL

WFS - 10 B 1 I

LINE SIZE

06 1/4" BSP 10 3/8"BSP 15 1/2"BSP
20 3/4"BSP 25 1"BSP 30 1 1/4"BSP

10

M.O.C. OF WETTED PARTS

S STAINLESS STEEL B BRASS

B

SWITCH TYPE

1 SPST 2 SPDT

1

LED INDICATOR

I LED INDICATOR*

I

* - For LED Indicator Current rating should be specified with order.